



**TESA**  
**TECOF**



*Sales Programme*



**HEXAGON METROLOGY**

# FAST ROUND PART INSPECTION

The whole TESA-Scan product line belongs to the range of dedicated non-contact opto-electronic measuring centres that provide Users with a complete solution for inspecting small round parts quickly. Including a variety of systems such as those usually integrated into profile projectors or microscopes, they offer the round part manufacturer a more capable alternative to traditional inspection methods. TESA's product range can measure shapes and sizes of round parts from 0,3 up to 130 mm in diameter, which can be as long as 1000 mm.



## Operating Principle

All TESA measuring centres incorporate high-resolution CCD linear sensors. Each sensor is subdivided into thousands of light sensitive pixels. As the part image is being projected, these sensors, which act as light sensitive rulers, can detect the slightest changes at sub-pixel level. The workpiece is illuminated with parallel white light and its image is projected onto the linear CCD sensors, which are inclined to 7,5°. They provide the information obtained from the image, thus allowing accurate analysis of the geometry of the workpiece features.

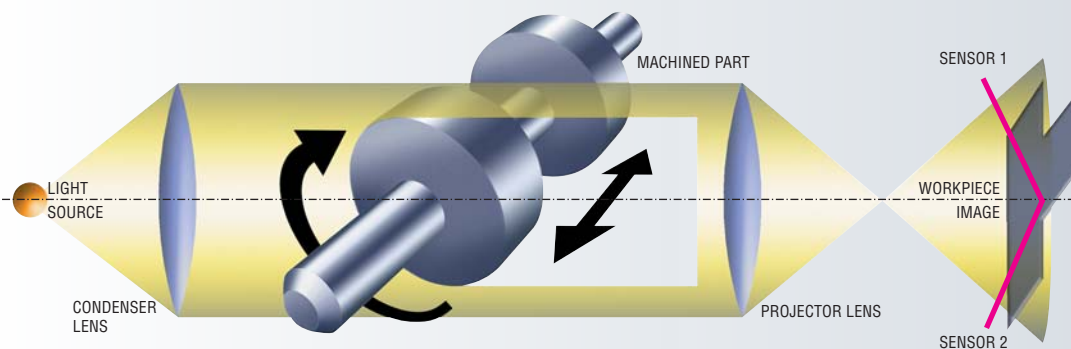

Complex part features such as straightness or circularity can easily be inspected by combining rotation with axial movement. This permits any surface of the workpiece to be scanned dynamically in order to determine the part axis for true 3D alignment and reference purposes.

## Dynamic Measurement

Rotation is a standard function of the inspection process, allowing a rotary scanning of the workpiece for highly accurate measurement of both the part geometry and shape, also with high speed.

## 2D Measurement

The part profile is obtained by scanning along the part axis. A two-axis image projection is produced as the workpiece diameter and length are being measured simultaneously.

A unique feature of these systems from TESA lies in the orientation of the linear sensors to 75° (10° for TESA-Scan 80) with respect to the workpiece axis, guaranteeing accurate measurement of all individual geometric elements such as angles, radii, diameters or any other part features with parallel or inclined surfaces.

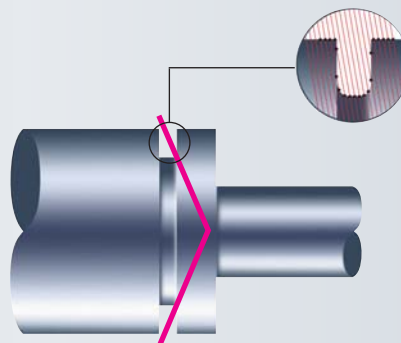



## Thread Measurement

External threads are important features of round parts, and their measurement is a high labour intensive operation. The true profile of any thread shape can be obtained with either Tesa-Scan system.

To measure shape and sizes or check worm threads, both TESA-Scan 50 Plus and TESA-Scan 80 Plus also offer a mechanism for tilting the workpiece to the helix angle in order to view the true size of the profile.

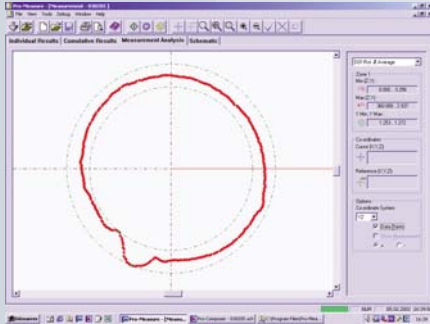
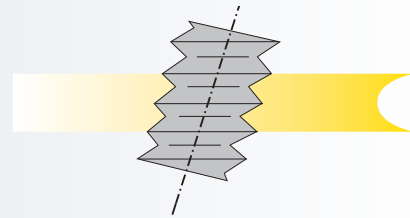

## Form and Shape Measurement

Sophisticated round part applications involving form and shape measurement are easily carried out using the flexible programming facility. Pro-Measure is a powerful software system, which allows a visual comparison of the true form obtained. This tool makes the analysis of manufacturing problems easier. It also provides the operator with a useful guidance when creating part programs.

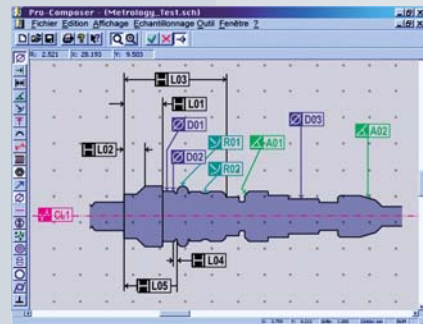

## Graphic Interface

Pro-Composer is an easy-to-use software tool for part programming created on the computer directly linked to the machine or off-line. It uses the graphic representation of the part profile created by scanning or importing the required geometry from a CAD file. For the programming sequence, the user simply selects the measurement function from the icon menu. For ease of use, all selected tolerances and parameter values can be retrieved based on the database available from international standards.



## Flexible Reporting

Pro-Measure enables the user to present all measurement data in a variety of numeric and graphic formats together with relevant process related information. Text, logos and Bitmap images can be included in the reports through the editing functions. Pro-Measure can easily be networked or interfaced to existing shop floor systems for data collection.

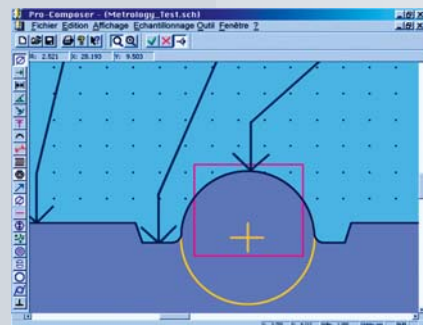

## Graphic Analysis

Pro-Composer allows visual inspection of lines and radii with a comparison of part data to given nominals available from the drawing. The results are then displayed in a graphic format. This option enables any defects occurring during a production run to be straightly eliminated, and is also very useful as debugging tool during part program creation.

## Comprehensive Reporting

Pro-Measure is a flexible software system that can accept data from other precision tools (e.g. those used for internal measuring). These data are then included into a single report. This software can be programmed so as to tell the operator that measurements taken by means of a handtool are required as the relevant inspection sequence will be starting or ending up.

## Part Programme Creation within Minutes

Pro-Measure further enhances the flexibility of the machine. This highly intuitive industrial software system is suited for each stage of the manufacturing process. In most cases, part program creation is only a matter of minutes.

## Performances

*(Valid for any type of machines)*

### Static measurement

*Diameters, lengths, intersection points, gauge diameters, radii, angles etc.*

*Two-axes workpiece alignment – Creating a workpiece axis based on two datum diameters.*

### Dynamic measurement

*Concentricity – Parallel and interrupted diameters, form diameter, taper, parallel thread profile.*

*Runout – Plain or interrupted diameters.*

*Roundness and cylindricity.*

*Diameters with rotation, ovality, max, min and average diameters of plain or interrupted diameters.*

*Hexagon – Across-flats, symmetry of flats to axis, max. dimension across corners.*

*Section analysis with rotation – Longest and shortest section of radii, angular location.*

*Three-axes workpiece alignment – Creating a workpiece axis with reference to plain diameters or thread lengths.*

### Thread measurement – With no mechanical tilting

- Parallel, vee-shaped threads
  - Major diameter
  - Flank diameter
  - Flank angle
  - Pitch
- Taper threads
  - Pitch
  - Flank angle
  - Included taper angle
  - Gauge length
  - Usable thread length
  - Pitch diameter
  - Major diameter

### Thread and worm thread measurement – With mechanical tilting

- Parallel threads
  - Major diameter
  - Flank diameter
  - Pitch
  - Minor diameter
  - Flank angle
  - Root radius
  - Crest radius
  - Circularity
  - Lead error
- Worm threads (on request)
  - Pitch
  - Major and minor diameters
  - Over Wire diameter
  - Tooth thickness
  - Pressure angle
  - Addendum
  - Dedendum
  - Thread depth
  - Runout
- Taper threads
  - Pitch diameter
  - Major diameter
  - Minor diameter
  - Taper
- Ball screws (on request)
  - Pitch
  - Lead error
  - Over wire diameter
- Double-threads, parallel
  - Major and minor diameters
  - Half pitch
  - Flank angle
  - Crest radius
  - Root radius

### Image cleaning

*The software includes a number of filters that can be selected at various levels to reduce the effect of contaminated workpieces.*

# TESA-Scan 25



840 x 640 x 460 mm,  
33 x 25 x 18 in

Diameter: 0,5 s  
Length: 0,5 s

Performances:  
see page P-4

100/110-220/240 VAC  
50/60 Hz

10 to 35°C  
50 to 95°F

10 to 80%



55 kg  
121 lbs

Shipping packaging

Inspection report with a declaration of conformity

Performances are based on the results obtained from clean, ground components measured at 20°C. They may be affected by the component shape and surface finish.

## Technical Data

	D mm	L mm	D in	L in	
Measuring capacity	25	200	1.0	8.0	
Component capacity	59	270	2.3	10.6	2 kg/ 4.4 lbs
Resolution	0,0002	0,001	0.00001	0.00004	
Accuracy (20°C ± 1°C)	1,5+(0,01 D) µm (D in mm)	6 + (0,01 L) µm (L in mm)	(0.06 + 0.01 D)/ 1000 in (D in in)	(0.24 + 0.01 L)/ 1000 in (L in in)	
Repeatability (±2s = 95%)	0,001	0,0025	0.00004	0.0001	



02430000

**TESA-Scan 25** (Ø 25 x L 200 mm). Measuring Centre with part rotation including 1 headstock Z173-3004, 1 tailstock Z125-3003 plus 2 male centres TL02-0001. Supplied with PC, mouse, installed **Windows XP Multilingual** operating system, TFT monitor 17", US keyboard, Pro-Measure/Pro-Composer with Handbook E-F-D on CD (order No. 02460011).

Pro-measure/  
Pro-Composer  
see page 11

## TESA-Scan 50

Measuring capacity:  
D = 50 mm, L = 275 mm



## TESA-Scan 50 C Plus

Measuring capacity:  
D = 50 mm,  
L = 275 mm

Equipped with slewing mechanism for thread measurement using advanced functions.

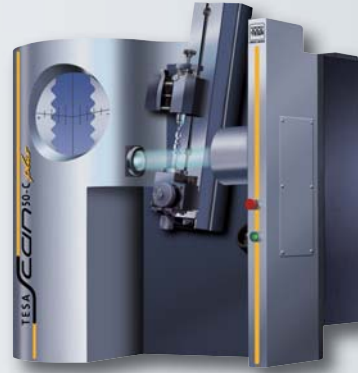

### Technical Data

	D mm	L mm	D in	L in	
<b>TESA-Scan 50</b>					
Measuring capacity	50	275	1.96	10.8	
Component capacity	100	290	3.9	11.4	4 kg/ 8.8 lbs
Resolution	0,0003	0,001	0.00001	0.00004	
Accuracy (20°C ± 1°C)	2 + (0,01 D) µm (D in mm)	7 + (0,01 L) µm (L in mm)	(0.08 + 0.01 D)/ 1000 in (D in in)	(0.28 + 0.01 L)/ 1000 in (L in in)	
Repeatability (±2s = 95%)	0,001	0,0025	0.00004	0.0001	

	D mm	L mm	D in	L in	
<b>TESA-Scan 50 C Plus</b>					
Measuring capacity	50	275	1.96	10.8	
Component capacity	100	290	3.9	11.4	4 kg/ 8.8 lbs
Tilting for thread measurement	max. 15°				
Resolution	0,0003	0,001	0.00001	0.00004	
Accuracy (20°C ± 1°C)	2 + (0,01 D) µm (D in mm)	7 + (0,01 L) µm (L in mm)	(0.08 + 0.01 D)/ 1000 in (D in in)	(0.28 + 0.01 L)/ 1000 in (L in in)	
Repeatability (±2s = 95%)	0,001	0,0025	0.00004	0.0001	

**No**

**=**

**02430010** **TESA-Scan 50** (Ø 50 x L 275 mm). Measuring Centre with part rotation. Basis machine including 1 headstock Z178-3004, 1 tailstock Z178-3003 plus 2 male centres TL02-0002. Supplied along with PC, mouse, installed **Windows XP Multilingual** operating system TFT monitor 17", US keyboard, Pro-Measure/Pro-Composer with Handbook E-F-D on CD (order No. 02460011).

**02430020** **TESA-Scan 50 C Plus** (Ø 50 x L 275 mm). Measuring Centre with rotation and slewing mechanism for thread measurement. Basis machine including 1 headstock Z178-3004, 1 tailstock Z178-3003 plus 2 male centres TL02-0002. Supplied along with PC, mouse, installed **Windows XP Multilingual** operating system, TFT monitor 17", US keyboard, Pro-Measure/Pro-Composer with Handbook E-F-D on CD (order No. 02460011).



1050 x 800 x 580 mm,  
41 x 32 x 23 in

Diameter: 0,5 s  
Length: 0,5 s

Performances:  
see page P-4

100/110-220/240 VAC  
50/60 Hz

10 to 35°C  
50 to 95°F

10 to 80%



115 kg, 250 lbs  
125 kg, 272 lbs

Shipping packaging

Inspection report with a declaration of conformity

*Performances are based on the results obtained from clean, ground components measured at 20 °C. They may be affected by the component shape and surface finish.*

Pro-measure/  
Pro-Composer  
see page 11



1050 x 800 x 580 mm,  
41 x 32 x 23 in

Diameter: 0,5 s  
Length: 0,5 s

Performances:  
see page P-4

100/110-220/240 VAC  
50/60 Hz

10 to 35°C  
50 to 95°F

10 to 80%



160 kg, 350 lbs

Shipping packaging

Inspection report with a declaration of conformity

## TESA-Scan 50 CE Plus

Measuring capacity: D = 50 mm, L = 275 mm

Equipped with slewing mechanism for thread measurement using advanced functions (tilting through to 30°).

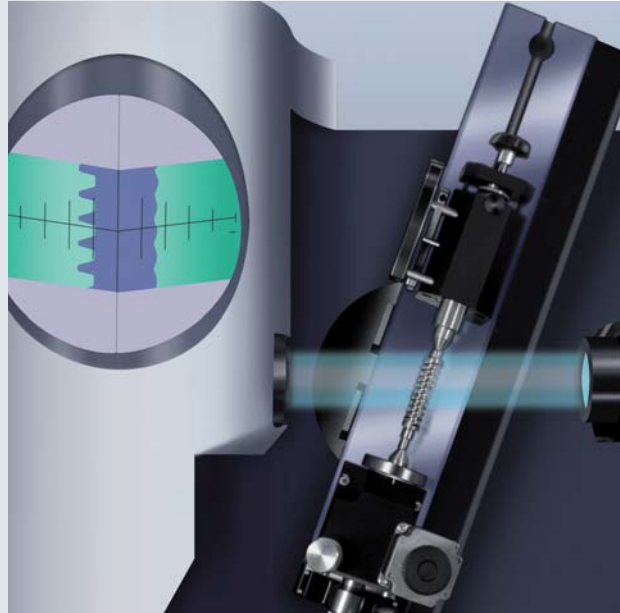

### Technical Data

	D mm	L mm	D in	L in	
Measuring capacity	50	275	1.96	10.8	
Component capacity	100	290	3.9	11.4	4 kg/ 8,8 lbs
Tilting for thread measurement	max. 30°				
Resolution	0,0003	0,001	0.00001	0.00004	
Accuracy (20°C ± 1°C)	2 + (0,01 D) µm (D in mm)	7 + (0,01 L) µm (L in mm)	(0.08 + 0.01 D)/ 1000 in (D in in)	(0.28 + 0.01 L)/ 1000 in (L in in)	
Repeatability (±2s = 95%)	0,001	0,0025	0.00004	0.0001	

Performances are based on the results obtained from clean, ground components measured at 20 °C. They may be affected by the component shape and surface finish.



**02430030** **TESA-Scan 50 CE Plus** (Ø 50 x L 275 mm). Measuring Centre with part rotation and slewing mechanism for thread measurement. Basis machine including 1 headstock Z178-3004, 1 tailstock Z178-3003 plus 2 male centres TL02-0002. Supplied along with PC, mouse, installed **Windows XP Multilingual** operating system, TFT monitor 17", US keyboard, Pro-Measure/Pro-Composer with Handbook E-F-D on CD (order No. 02460011).

Pro-measure/  
Pro-Composer  
see page 11

## TESA-Scan 50 Plus

Measuring capacity: D = 50 mm, L = 500 mm

Equipped with slewing mechanism for thread measurement using advanced functions.

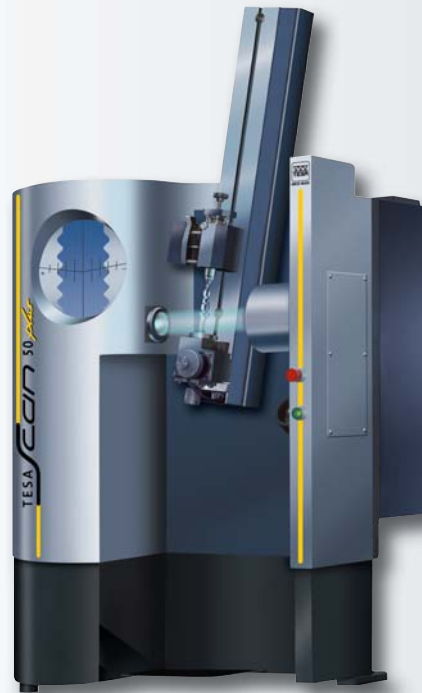

1450 x 800 x 580 mm, 57 x 32 x 23 in



Diameter: 0,5 s  
Length: 0,5 s



Performances: see page P-4



100/110-220/240 VAC  
50/60 Hz



10 to 35°C  
50 to 95°F



10 to 80%



160 kg, 350 lbs



Shipping packaging



Inspection report with a declaration of conformity

### Technical Data

	D mm	L mm	D in	L in	
Measuring capacity	50	500	1.96	19.7	
Component capacity	100	515	3.9	20.3	6 kg/ 13,2 lbs
Tilting for thread measurement	max. 15°				
Resolution	0,0003	0,001	0.00001	0.00004	
Accuracy (20°C ± 1°C)	2 + (0,01 D) µm (D in mm)	7 + (0,01 L) µm (L in mm)	(0.08 + 0.01 D)/ 1000 in (D in in)	(0.28 + 0.01 L)/ 1000 in (L in in)	
Repeatability (±2s = 95%)	0,001	0,0025	0.00004	0.0001	

Performances are based on the results obtained from clean, ground components measured at 20 °C. They may be affected by the component shape and surface finish.

**No**



**02430040** **TESA-Scan 50 Plus** (Ø 50 x L 500 mm). Measuring Centre with part rotation and slewing mechanism for thread measurement. Basis machine including 1 headstock Z178-3004, 1 tailstock Z178-3003 plus 2 male centres TL02-0002. Supplied along with PC, mouse, installed **Windows XP Multilingual** operating system, TFT monitor 17", US keyboard, Pro-Measure/Pro-Composer with Handbook E-F-D on CD (order No. 02460011).

Pro-measure/  
Pro-Composer  
see page 11

# TESA-Scan 80 / 80 Plus



1500 x 750 x 520 mm,  
60 x 30 x 20 in



Diameter: 0,5 s  
Length: 0,5 s



Performances:  
see page P-4



100/110-220/240 VAC  
50/60 Hz



10 to 35°C  
50 to 95°F



10 to 80%



250 kg, 552 lbs  
260 kg, 574 lbs



Shipping packaging



Inspection report with a declaration of conformity

## Technical Data

	D mm	L mm	D in	L in	
Measuring capacity	80	500	3.1	19.7	
Component capacity	100	515	3.9	20.3	6 kg/ 13.2 lbs
Tilting for thread measurement	(80 Plus) max. helix angle 10°				
Resolution	0,0002	0,001	0.00001	0.00004	
Accuracy Ø <30 mm	1,5+(0,01 D) µm (D in mm)	7 + (0,01 L) µm (L in mm)	(0.06 + 0.01 D)/ 1000 in (D in in)	(0.28 + 0.01 L)/ 1000 in (L in in)	
Ø >30 mm (20°C ± 1°C)	2 + (0,01 D) µm (D in mm)	8 + (0,01 L) µm (L in mm)	(0.08 + 0.01 D)/ 1000 in (D in in)	(0.35 + 0.01 L)/ 1000 in (L in in)	
Repeatability (±2s = 95%)	0,001	0,003	0.00004	0.00012	
Air supply	4-6 bar		60-90 PSI		

Performances are based on the results obtained from clean, ground components measured at 20 °C. They may be affected by the component shape and surface finish.



02430050



**TESA-Scan 80** (Ø 80 x L 500 mm). Measuring Centre with part rotation. Basis machine including 1 headstock Z178-3004, 1 tailstock Z178-3003 plus 2 male centres TL02-0002. Supplied along with PC, mouse, installed **Windows XP Multilingual** operating system, TFT monitor 17", US keyboard, Pro-Measure/Pro-Composer with Handbook E-F-D on CD (order No. 02460011).

02430060

**TESA-Scan 80 Plus** (Ø 80 x L 500 mm). Measuring Centre with protective enclosure, part rotation and slewing mechanism for thread measurement. Basis machine including 1 headstock Z178-3004, 1 tailstock Z178-3003 plus 2 male centres TL02-0002. Supplied along with PC, mouse, installed **Windows XP Multilingual** operating system, TFT monitor 17", US keyboard, Pro-Measure/Pro-Composer with Handbook E-F-D on CD (order No. 02460011).

Pro-measure/  
Pro-Composer  
see page 11

# TESA-Scan 100 / 130



- ✓
- 2234 x 988 x 943 mm, 88 x 38.9 x 37.2 in
- Diameter: 0,5 s  
Length: 0,5 s
- Performances: see page P-4
- 100/110-220/240 VAC  
50/60 Hz
- 10 to 35°C  
50 to 95°F
- 10 to 80%
- ✓
- 700 kg, 1545 lbs
- Shipping packaging
- Inspection report with a declaration of conformity

## Technical Data

	D mm	L mm	D in	L in	
Measuring capacity	100/130	800	3.94/5.1	31.5	
Component capacity	250	850	9.84/9.84	33.5	30 kg/ 66 lbs
Resolution	0,0002	0,001	0.00001	0.00004	
Accuracy	2 + (0,01 D) µm (D in mm)	8 + (0,01 L) µm (L in mm)	(0.08 + 0.01 D)/ 1000 in (D in in)	(0.28 + 0.01 L)/ 1000 in (L in in)	
Repeatability (±2s = 95%)	0,001	0,003	0.00004	0.00012	
Air supply	6 bar		90 PSI		

*Performances are based on the results obtained from clean, ground components measured at 20°C. They may be affected by the component shape and surface finish.*

**No**

**=**

- 02430071** **TESA-Scan 100** (Ø 100 x L 800 mm). Measuring Centre with part rotation. Basis machine including 1 headstock, 1 tailstock plus 2 male centres. Supplied along with PC, mouse, installed **Windows XP Multilingual** operating system, TFT monitor 17", US keyboard, Pro-Measure/Pro-Composer with Handbook E-F-D on CD (order No. 02460011).
- 02430070** **TESA-Scan 130** (Ø 130 x L 800 mm). Measuring Centre with protective enclosure, part rotation and slewing mechanism for thread measurement. Basis machine including 1 headstock Z178-3004, 1 tailstock Z178-3003 plus 2 male centres TL02-0002. Supplied along with PC, mouse, installed **Windows XP Multilingual** operating system, TFT monitor 17", US keyboard, Pro-Measure/Pro-Composer with Handbook E-F-D on CD (order No. 02460011).

Pro-measure/  
Pro-Composer  
see page 11

## Software and Interfaces

*Software*

<b>02460011</b>	Pro-Measure/Pro-Composer along with hard-key plus Handbook in English, French and German on CD. Another version can additionally be made available for off-line programming.
<b>02460010</b>	Pro-Measure/Pro-Composer (CD only)

*Interfaces*

<b>XS01-0001</b>	Gageport NT interface for inductive probe, 2 probe inputs
<b>XS01-0011</b>	Gageport NT interface, digital, 2 probe inputs
<b>XS01-0008</b>	Gageport NT interface, digital, 4 probe inputs
<b>XS01-0010</b>	Extension unit for inductive probes, 8 probe inputs
<b>XS01-0013</b>	Gageport extension box (for 4 modules)
<b>04761061</b>	*Connecting cable Gageport to PC
<b>04761054</b>	*Power supply
<b>04761055</b>	*EU connecting cable
<b>04761056</b>	*US connecting cable

\* Instead of XS00-0006

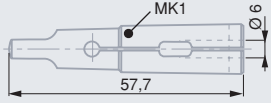
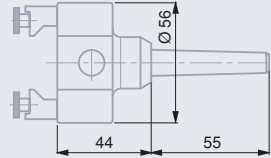
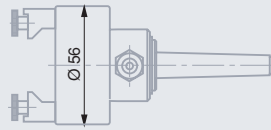
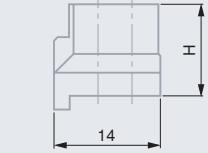
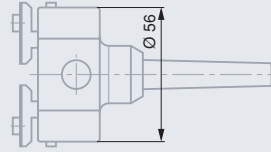
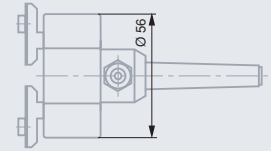
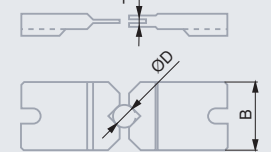

Accessories

Order Number		Morse 1 TESA-Scan 25	Morse 2 TESA-Scan 50 TESA-Scan 80	Notes	Description
TL01-0002		●	—	—	Centre adapter with a 6 mm dia. coupling bore
TL01-0003		●	● Requires TL01-0027	External clamping for manual use	Two-jaw gripper
TL01-0004		●	● Requires TL01-0027	External clamping for use with air pressure	Two-jaw gripper
TL01-0005 H = 18 TL01-0006 H = 22		For TL01-0003 TL01-0004	—	—	Raising blocks for external jaws, in pairs
TL01-0007		●	● Requires TL01-0027	Internal clamping for manual use	Two-jaw gripper
TL01-0008		●	● Requires TL01-0027	Internal clamping for use with air pressure	Two-jaw gripper
TL01-0009 0÷6 mm T = 1,5 TL01-0010 0÷6 mm T = 3 TL01-0011 6÷12 mm T = 3 TL01-0012 12÷18 mm T = 6 TL01-0013 18÷24 mm T = 9 TL01-0038 0÷6 mm T = 6 TL01-0039 0÷6 mm T = 15 TL01-0040 6÷12 mm T = 15		For TL01-0003 TL01-0004	—	—	External jaws, in pairs
TL01-0021	Set of jaws including: TL01-0009 TL01-0010 TL01-0011 TL01-0012 TL01-0013	For TL01-0003 TL01-0004	—	—	External jaws, in pairs



Order Number		Morse 1 TESA-Scan 25	Morse 2 TESA-Scan 50 TESA-Scan 80	Notes	Description
<p><b>TL01-0015</b> D = 4-5 mm H = 6,6 mm</p> <p><b>TL01-0016</b> D = 5-6 mm H = 8,6 mm</p> <p><b>TL01-0017</b> D = 6-8 mm H = 11,5 mm</p> <p><b>TL01-0018</b> D = 8-11 mm H = 17,5 mm</p> <p><b>TL01-0019</b> D = 11-15 mm H = 20 mm</p> <p><b>TL01-0020</b> D = 15-19 mm H = 20,2 mm</p>		For TL01-0007 TL01-0008	-	-	Internal jaws, in pairs
<b>TL01-0022</b>	Set of jaws including: TL01-0015 TL01-0016 TL01-0017 TL01-0018 TL01-0019 TL01-0020	For TL01-0007	-	-	Internal jaws, in pairs
<b>TL01-0026</b>		-	●	-	Centre adapter with a 6 mm dia. coupling bore
<b>TL01-0027</b>		-	●	-	Reduction sleeve, Morse 2 to 1
<b>TL02-0001</b>		●	-	2 items provided with TESA-Scan 25	Extra male centre, 10 mm
<b>TL02-0002</b>		-	●	2 items provided with TESA-Scan 50 TESA-Scan 80	Extra male centre, 17 mm
<b>TL02-0003</b>		●	-	Diamond coated 10 mm	Drive centre
<b>TL02-0016</b>		●	-	For added sleeves Z173- 0922/0923	Rotation centre with a B12 male taper plus a Morse 1 taper shank



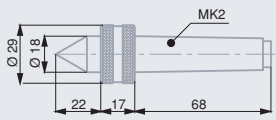
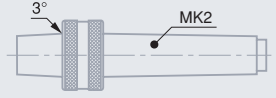
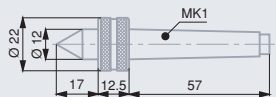
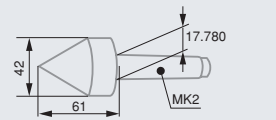
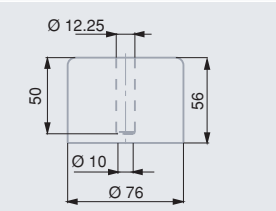
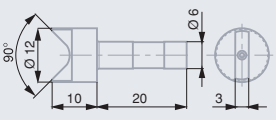
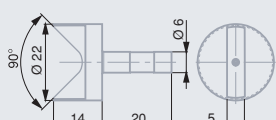
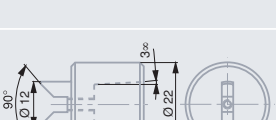
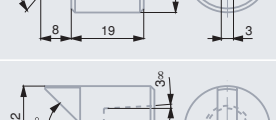
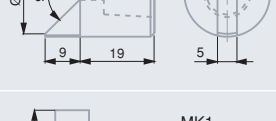
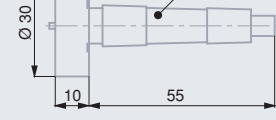
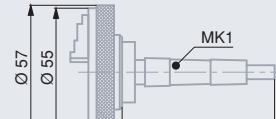
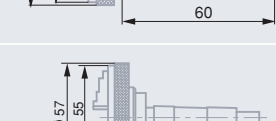



















Order Number		Morse 1 TESA-Scan 25	Morse 2 TESA-Scan 50 TESA-Scan 80	Notes	Description
TL02-0017		-	●	-	Rotation centre, Morse 2
TL02-0018		-	●	-	Rotation centre with a B12 male taper plus a Morse 1 shank
TL02-0019		●	-	-	Rotation centre, Morse 1
TL02-0021		-	●	-	Rotation centre, Morse 2
Z173-0908		For TL01-0003 TL01-0004 TL01-0007 TL01-0008	-	Ensures stable positioning for mounting jaws	Vertical support
Z173-0920		● Requires TL01-0002	● Requires TL01-0026	-	Female centre, 10 mm dia.
Z173-0921		● Requires TL01-0002	● Requires TL01-0026	-	Female centre, 20 mm dia.
Z173-0922		● Requires TL02-0016	-	-	Female centre, 10 mm dia. Also with internal B12 taper
Z173-0923		● Requires TL02-0016	-	-	Female centre, 10 mm dia. Also with internal B12 taper
Z173-0961		●	-	-	Platten, 30 mm dia.
Z173-2020		●	● Requires TL01-0027	Clamping capacity: outside 1÷15 mm inside 11÷26 mm	3-jaw chuck, clamping range 1÷15 mm
Z173-2024		-	●	-	6-jaw chuck, clamping range 0,7÷15 mm
Z173-2025		●	-	-	

Order Number		Morse 1 TESA-Scan 25	Morse 2 TESA-Scan 50 TESA-Scan 80	Notes	Description
Z178-2009		-	●	Used to drive components between fixed centres. Directly fitted on the headstock.	Drive mechanism
Z178-2020		-	●	Clamping capacity: outside 2÷50 mm inside 23÷50 mm	3-jaw chuck with Morse 2 taper shank, clamping range 2÷50 mm
Z178-2025		-	●	-	Platten, 80 mm dia. Also with a Morse 2 taper shank
Z178-2026		-	●	Diamond coated	Drive centre, Ø 40 mm. Also with a Morse 2 taper shank
Z178-0607		-	●	-	Female centre, 40 mm dia. Also with a Morse 2 taper shank
Z178-0610		-	●	-	Male centre, 15÷40 mm dia. Also with a Morse 2 taper shank
Z178-0940		-	●	Requires TL02-0018	Female centre, 10 mm dia., Also with a B12 internal taper
Z178-0941		-	●	Requires TL02-0018	Female centre, 10 mm dia., Also with a B12 internal taper
Z178-0942		-	●	Requires TL02-0018	Female centre, 10 mm dia., Also with a B12 internal taper
Z178-3028		-	●	-	Drive centre, 42 mm dia. max.



## Lexicon of pictograms

 TESA Design SWISS MADE	 Repeatability limit	 Notes	 Mass
 Order number	 Dimensions	 Power supply	 Packaging
 Measuring range Measuring span	 Diameter	 Working temperature range	 Declaration of conformity
 Numerical interval	 Maximum displacement speed	 Maximum relative humidity	 Inspection report with a declaration of conformity
 Maximum permissible errors Limit deviations	 Special features	 Electromagnetic compatibility	 TESA

**TESA SA Switzerland**  
Bugnon 38  
CH-1020 Renens

Tél. +41 (0)21 633 16 00  
Fax +41 (0)21 633 17 57  
tesa-ventech@hexagonmetrology.com

**TESA FRANCE SAS**  
13-15, av. Georges de La Tour  
FR-54303 Lunéville Cedex

Tél. +33 (0)3 83 76 83 76  
Fax +33 (0)3 83 74 13 16  
tesa-france@hexagonmetrology.com

**TESA Technology  
Deutschland GmbH**

Netzstraße 32  
DE-71638 Ludwigsburg  
Tel. +49 (0)7141 8747 0  
Fax +49 (0)7141 8747 88  
tesa-de@hexagonmetrology.com

**TESA Technology UK Ltd.**

Metrology House  
Halesfield 13  
GB-Telford, Shrops. TF7 4PL  
Tel. +44 1952 681 349  
Fax +44 1952 681 391  
tesa-uk@hexagonmetrology.com

**TESA Technology  
ITALIA s.r.l.**

Bugnon 38  
CH-1020 Renens  
Tél. +41 (0)21 633 16 00  
Fax +41 (0)21 633 17 57  
tesa-ventech@hexagonmetrology.com

**TESA Technology Ibérica**

Av. de Vizcaya s/n  
Apart. 202  
ES-48260 Ermua  
Tel. +34 943 170 340  
Fax +34 943 172 092  
tesa-iberica@hexagonmetrology.com

**TESA Benelux**

Pascal Siebens  
Gaal de Wittellaan 17, Bus 21  
BE-2800 Mechelen  
Tel. +32 (0)15 435 301  
Fax +32 (0)15 435 302  
tesa-benelux@hexagonmetrology.com

**Hexagon Metrology  
Nordic AB**

Filargatan 3  
SE-631 81 Eskilstuna  
Tel. +46 16 160800  
Fax +46 16 160890  
order.se@hexagonmetrology.com

Headquarters: TESA SA – Bugnon 38 – CH-1020 Renens – Switzerland – Tel. +41(0)21 633 16 00 – Fax +41(0)21 635 75 35 – www.tesabs.ch – tesa-info@hexagonmetrology.com